

parameters, while for  $\text{OsF}_6^-$  the data required  $a_3^2 k = 0.4$ . However, the latter result proved very sensitive to the values assumed for the free-ion parameters and was felt to be too low, while the estimation of  $a_5^2$  is not possible in any case. Moreover, Gerloch and Miller<sup>26</sup> have shown that the presumed equivalence of  $k$  and  $a_5^2$  is invalid and that the extent of delocalization of the  $t_{2g}$  set is normally appreciably underestimated by the orbital reduction factor.

Consequently the effective spin-orbit coupling constants for  $\text{OsF}_6^-$  and  $\text{IrF}_6^-$  can probably be determined

(26) M. Gerloch and J. R. Miller, *Progr. Inorg. Chem.*, **10**, 1 (1968).

more accurately from the electronic spectra, especially for  $\text{IrF}_6^-$  where the spin-orbit splitting of the ground state is directly observable. Naturally the extent of the estimated nephelauxetic and relativistic effects depends closely on the free-ion parameters assumed, which are subject to an appreciable uncertainty. We are therefore attempting to assess the consistency of our parameterization by studying other 5d hexahalo complexes,<sup>24</sup> particularly those of Os(IV) and Ir(IV) in which the spin-orbit splitting of the ground levels allows good estimates of the effective spin-orbit coupling constants of the complexes to be made.

CONTRIBUTION FROM THE CHRISTOPHER INGOLD LABORATORIES,  
UNIVERSITY COLLEGE, LONDON, ENGLAND

## Vapor-Phase Raman Spectra, Force Constants, and Values for Thermodynamic Functions of the Tetrachlorides, Tetrabromides, and Tetraiodides of Titanium, Zirconium, and Hafnium

BY R. J. H. CLARK,\* B. K. HUNTER, AND D. M. RIPPON

Received April 29, 1971

The Raman spectra of titanium tetrachloride (at 65°), titanium tetrabromide (at 125°), and the tetrachlorides, tetrabromides, and tetraiodides of zirconium and hafnium (at 380–420°) have been recorded in the vapor phase, and values for all the fundamentals of these molecules are presented. The  $\nu_2(e)$  and  $\nu_4(t_2)$  modes have pronounced rotational structure in each case. Although the zirconium and hafnium tetrahalides are polymeric in the solid state, their Raman spectra are interpreted to indicate that all are tetrahedral monomers in the vapor phase and thus isostructural with the titanium tetrahalides (which are tetrahedral in all states of matter). Force constants have been calculated for all the halides, including titanium tetraiodide (by the use of solution data) on the bases of both the modified-valence force field as well as the Urey-Bradley force field. Values for various thermodynamic functions have also been computed for each halide.

The tetrahalides of zirconium and hafnium have closely similar physical properties on account of the near identity of the radii of the two group IV metal atoms. In view of the technological interest in the separation of zirconium from hafnium and the role of the tetraiodides in the van Arkel-de Boer process for the preparation of the pure metals, the thermodynamic properties of the tetrahalides in the vapor phase acquire considerable practical importance. The properties may be calculated from a knowledge of the frequencies of the various fundamentals for molecules of known structure. Although the tetrahalides of titanium are tetrahedral monomers in all states of matter,<sup>1</sup> this is not the case for those of zirconium and hafnium. In the solid state, the halides  $\text{MX}_4$  ( $M = \text{Zr}$  or  $\text{Hf}$ ,  $X = \text{Cl}$  or  $\text{Br}$ ) consist<sup>2</sup> of zigzag chains, each metal atom being octahedrally coordinated to halogen atoms, two of which are terminal and two bridging, *viz.*  $[\text{MX}_{1/2}\text{X}_2]_\infty$ . The structures of the solid tetraiodides are uncertain. By contrast with the data for the solid state, electron diffraction data on zirconium tetrachloride<sup>3–5</sup> and on hafnium tetrachloride<sup>5</sup> indicate that in the vapor phase

these molecules are monomeric and tetrahedral. Infrared data<sup>6</sup> on the same two halides in the vapor phase have been interpreted on this basis, one fundamental,  $\nu_3(t_2)$ , having been found directly in each case. Vapor density measurements on zirconium tetrabromide and zirconium tetraiodide have shown that these halides also are monomeric in the vapor phase.<sup>7</sup> It remains to be shown that they, as well as the tetrabromides and tetraiodides of hafnium, are tetrahedral in the vapor phase. The present Raman data establish this conclusively.

Values for all the fundamentals of the group IVA tetrahalides (excepting the fluorides) have been determined, and appropriate force constants have been calculated on the modified-valence force field and Urey-Bradley force-field models. Values for various thermodynamic functions of each of the halides have also been calculated and are tabulated. A preliminary publication on this work has appeared.<sup>8</sup>

### Experimental Section

**Compounds.**—The sources of the tetrahalides were as follows: British Drug Houses ( $\text{TiCl}_4$ ,  $\text{ZrCl}_4$ ); Alfa Inorganics ( $\text{TiBr}_4$ ,  $\text{TiI}_4$ ,  $\text{ZrBr}_4$ ,  $\text{ZrI}_4$ ,  $\text{HfCl}_4$ ,  $\text{HfBr}_4$ , and  $\text{HfI}_4$ ).

(6) (a) J. K. Wilmshurst, *J. Mol. Spectrosc.*, **5**, 343 (1960); (b) A. Büchler, J. B. Berkowitz-Mattuck, and D. H. Dugre, *J. Chem. Phys.*, **34**, 2202 (1961).

(7) W. Fischer and O. Rahlfs, *Z. Elektrochem. Angew. Phys. Chem.*, **38**, 592 (1932).

(8) R. J. H. Clark, B. K. Hunter, and D. M. Rippon, *Chem. Ind. (London)*, 787 (1971).

(1) R. J. H. Clark, "The Chemistry of Titanium and Vanadium," Elsevier, Amsterdam, 1968.

(2) B. Krebs, *Z. Anorg. Allg. Chem.*, **378**, 263 (1970).

(3) M. W. Lister and L. E. Sutton, *Trans. Faraday Soc.*, **37**, 393 (1941).

(4) M. Kimura, K. Kimura, M. Aoki, and S. Shibata, *Bull. Chem. Soc. Jap.*, **29**, 95 (1956).

(5) V. P. Spiridonov, P. A. Akishin, and V. I. Tsiref'nikov, *J. Struct. Chem. (USSR)*, **3**, 311, (1962).

The iodides were found to be insufficiently pure as supplied, there being oxide and/or oxyiodide as well as iodine impurity present. Whereas the presence of the oxo compounds was not serious, owing to their low volatility, the presence of even very small amounts of iodine rendered the recording of the Raman spectrum of a tetraiodide impossible owing to (a) absorption of the scattered beam and (b) the excitation of the very strong resonance fluorescence<sup>9</sup> spectrum of iodine.

Titanium tetraiodide was purified by four consecutive sublimations. Zirconium and hafnium tetraiodides were purified by chemical transport *in vacuo* in a sealed tube *ca.* 18 in. long, the ends of which were held at *ca.* 440° (end A) and 20° (end B) and the center portion of which was held at *ca.* 170°. The impure tetraiodide was placed at end A prior to the appropriate temperature gradient being set up. After *ca.* 24 hr, all the iodine was transported to the cold end of the tube, and the pure tetraiodide was transported to the center region of the tube, while the oxo impurities remained at the hot end of the tube. The pure tetraiodide was then sealed into a vacuum manifold.

**Instruments.**—The Raman spectra were recorded using a Spex 1401 spectrometer in conjunction with Coherent Radiation Laboratories Ar<sup>+</sup> and Kr<sup>+</sup> lasers. The scattered radiation was collected at 90° and focused by an *f*/0.95 lens onto the entrance slit of the monochromator after having been passed through a polarization scrambler. The 0.75-m Czerny–Turner monochromator employed two 1200 lines/mm Bausch and Lomb gratings blazed at 5000 Å. The method of detection was photon counting (cooled FW 130 phototube) and the presentation of the spectra was linear in response. The power available at the exciting wavelengths used, 4880 and 5145 Å of the Ar<sup>+</sup> laser, was *ca.* 1.3 W and *ca.* 1.6 W, respectively. The spectra were calibrated by reference to the emission lines of argon and neon. The spectral slit width was *ca.* 1 cm<sup>-1</sup>.

The samples were sealed into small Pyrex tubes *ca.* 2 cm long. The tubes were held inside a small furnace as shown in Figure 1,

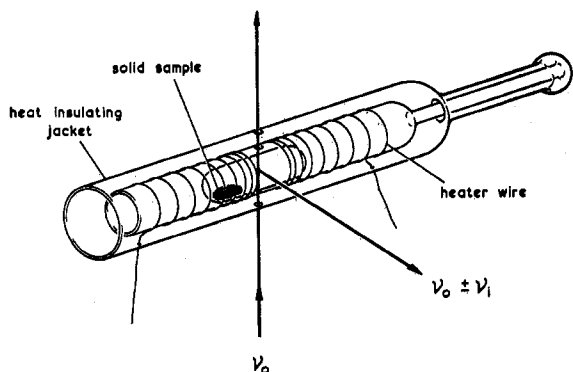

Figure 1.—Hot cell used in conjunction with the recording of the Raman spectra of the tetrahalides in the gas phase.

the temperature inside of which could be controlled by a transformer. The spacings between the wire wound around the inner tube were arranged so that a temperature gradient was produced with the hottest part of the furnace being directly in the path of the laser beam. This was necessary in order that any sublimation of the sample would be away from the path of the laser beam and thus interference with the incident and scattered beam by the sublimate would be avoided.

### Results and Discussion

The procedure was adopted of recording the spectrum of any tetrahalide at the lowest temperature for which the signal:noise ratio of the Raman spectrum was acceptable. Although the volatility of the tetrahalides is in the order chloride > bromide > iodide, the order of metal–halogen bond polarizability derivatives is the reverse<sup>10</sup> so that for any given metal atom the spectra of the chloride, bromide, and iodide were in fact recorded at rather similar temperatures. The

(9) I. R. Beattie, G. A. Ozin, and R. O. Perry, *J. Chem. Soc. A*, 2071 (1970).

(10) R. J. H. Clark and C. J. Willis, *Inorg. Chem.*, **10**, 1118 (1971).

values found for the various fundamentals are listed in Table I, together with the known or estimated metal–

TABLE I  
FUNDAMENTAL FREQUENCIES OF THE GROUP IVA  
TETRACHLORIDES, TETRABROMIDES, AND  
TETRAIODIDES (MX<sub>4</sub>) IN THE VAPOR STATE

Halide	cm <sup>-1</sup>				T, °C	r(MX), Å	B, cm <sup>-1</sup>
	ν <sub>1</sub> (a <sub>1</sub> )	ν <sub>2</sub> (e)	ν <sub>3</sub> (t <sub>2</sub> )	ν <sub>4</sub> (t <sub>2</sub> )			
TiCl <sub>4</sub>	389	114	498	136	65	2.17 <sup>a</sup>	0.03787
TiBr <sub>4</sub>	231.5	68.5	393	88	125	2.31 <sup>b</sup>	0.01483
TiI <sub>4</sub> <sup>c</sup>	162	51	323	67	20 <sup>c</sup>	2.50 <sup>d</sup>	0.00797
ZrCl <sub>4</sub>	377	98	418	113	380	2.32 <sup>e</sup>	0.03313
ZrBr <sub>4</sub>	225.5	60	315	72	380	2.44 <sup>f</sup>	0.01329
ZrI <sub>4</sub>	158	43	254	55	420	2.64 <sup>d</sup>	0.00715
HfCl <sub>4</sub>	382	101.5	390	112	380	2.33 <sup>e</sup>	0.03284
HfBr <sub>4</sub>	235.5	63	273	71	380	2.43 <sup>f</sup>	0.01340
HfI <sub>4</sub>	158	55	224	63	420	2.63 <sup>d</sup>	0.00720

<sup>a</sup> Y. Morino and H. Uehara, *J. Chem. Phys.*, **45**, 4543 (1966).

<sup>b</sup> M. W. Lister and L. E. Sutton, *Trans. Faraday Soc.*, **37**, 393 (1941).

<sup>c</sup> Data refer to cyclohexane solutions: R. J. H. Clark and C. J. Willis, *J. Chem. Soc. A*, 838 (1971).

<sup>d</sup> Estimated value.

<sup>e</sup> V. P. Spiridonov, P. A. Akishin, and V. I. Tsirel'nikov, *J. Struct. Chem. (USSR)*, **3**, 311 (1962).

<sup>f</sup> I. A. Cherkasov, quoted by S. S. Berdonosov, D. G. Berdonosova, A. V. Lapitskii, and L. G. Vlasov, *Russ. J. Inorg. Chem.*, **8**, 277 (1963).

<sup>g</sup> ν<sub>1</sub> and ν<sub>2</sub> both have sharp Q branches (with the exception of ν<sub>2</sub> in HfI<sub>4</sub>) and are considered accurate to ±1 cm<sup>-1</sup>.

ν<sub>3</sub> is broader and is considered accurate to ±2 cm<sup>-1</sup>.

ν<sub>4</sub> is weaker than ν<sub>2</sub> and its Q branch is difficult to locate; its frequency is considered accurate to ±3 cm<sup>-1</sup>.

ν<sub>4</sub> is weaker than ν<sub>2</sub> and its Q branch is difficult to locate; its frequency is considered accurate to ±3 cm<sup>-1</sup>.

ν<sub>4</sub> is weaker than ν<sub>2</sub> and its Q branch is difficult to locate; its frequency is considered accurate to ±3 cm<sup>-1</sup>.

ν<sub>4</sub> is weaker than ν<sub>2</sub> and its Q branch is difficult to locate; its frequency is considered accurate to ±3 cm<sup>-1</sup>.

halogen bond lengths and the B values calculated therefrom.

Although the Raman spectra of titanium tetrachloride and titanium tetrabromide have long been known in the liquid state,<sup>11</sup> there has been no report of their vapor-phase Raman spectra. On the other hand, the vapor-phase infrared spectrum of titanium tetrachloride has been reported,<sup>12</sup> the values for the fundamentals being as follows: ν<sub>1</sub>, 388; ν<sub>2</sub>, 119; ν<sub>3</sub>, 498.5; ν<sub>4</sub>, 139 cm<sup>-1</sup> (ν<sub>3</sub> was observed directly, whereas ν<sub>1</sub>, ν<sub>2</sub>, and ν<sub>4</sub> were deduced from combination bands). The values for ν<sub>1</sub> and ν<sub>3</sub> are in excellent agreement with those reported herein, but the values for ν<sub>2</sub> and ν<sub>4</sub> are 3–5 cm<sup>-1</sup> higher than those reported herein. A later report<sup>13</sup> of the vapor-phase infrared spectrum of titanium tetrachloride places ν<sub>4</sub> at 136 cm<sup>-1</sup>, in exact agreement with the value reported herein. The liquid state Raman values for the fundamentals of titanium tetrabromide (ν<sub>1</sub> 229.5; ν<sub>2</sub> 74; ν<sub>3</sub> 384; ν<sub>4</sub> 90.5 cm<sup>-1</sup>)<sup>14</sup> differ by up to 9 cm<sup>-1</sup> from the present vapor-phase data. The vapor-phase Raman spectra of these two halides are shown in Figures 2 and 3. All attempts to obtain the vapor-phase Raman spectrum of titanium tetraiodide were unsuccessful due to its decomposition in the laser beam (6471-Å excitation, 700 mW). Accordingly, subsequent calculations were carried out by use of data pertaining to cyclohexane solutions.<sup>15</sup>

The only previous reports of the Raman spectra of the zirconium or hafnium tetrahalides refer to spectra of zirconium tetrachloride as a melt in phosphorus oxytrichloride and in phosphorus pentachloride.<sup>16</sup> Unfortunately, it is not certain what the scattering

(11) P. Pascal, Ed., "Nouveau Traité de Chimie Minérale," Vol. 9, Masson, Paris, 1963.

(12) N. J. Hawkins and D. R. Carpenter, *J. Chem. Phys.*, **23**, 1700 (1955).

(13) H. Bürger and A. Ruoff, *Spectrochim. Acta, Part A*, **24**, 1863 (1968).

(14) F. A. Miller and G. L. Carlson, *ibid.*, **16**, 6 (1960).

(15) R. J. H. Clark and C. J. Willis, *J. Chem. Soc. A*, 838 (1971).

(16) M. L. Delwaille and M. F. François, *Bull. Soc. Chim. Fr.*, 205 (1946); *J. Phys. Radium*, **7**, 15 (1946).

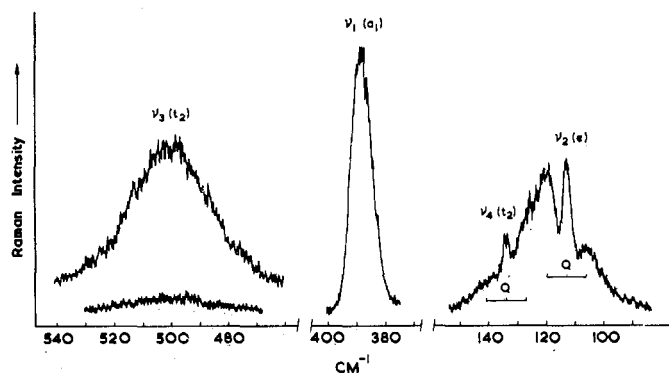

Figure 2.—Raman spectrum of titanium tetrachloride at 65° in the vapor phase (5145-Å excitation). Instrument settings: scanning speed 10 cm<sup>-1</sup>/min, gain 500 counts/sec, time constant 1 sec, slits 70/200/70 μ; inset for ν<sub>3</sub>, settings identical except for gain 200, time constant 2 sec, slits 100/200/100 μ.

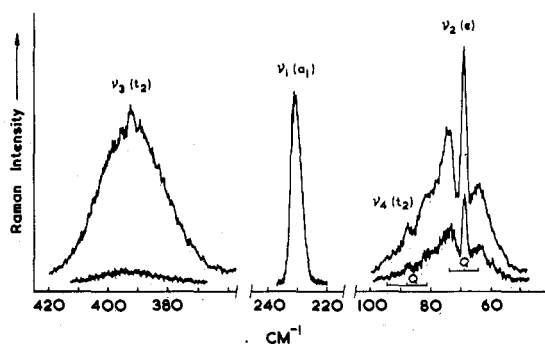

Figure 3.—Raman spectrum of titanium tetrabromide at 125° in the vapor phase (5145-Å excitation). Instrument settings: scanning speed 10 cm<sup>-1</sup>/min, gain 500 counts/sec, time constant 1 sec, slits 30/200/30 μ; inset for ν<sub>3</sub>, settings identical except for time constant 2 sec, slits 80/200/80 μ; inset for ν<sub>2</sub> and ν<sub>4</sub>, settings as for main scan except for time constant 2 sec, slits 35/200/35 μ.

species are in these media.<sup>17</sup> The Raman spectrum of zirconium tetrachloride in the solid state has also been reported,<sup>18</sup> these data referring therefore to the six-coordinate polymeric form.

The vapor-phase spectra of the zirconium and hafnium tetrahalides are new, and the assignments therefore require comment. One band in the spectrum of each compound is completely polarized ( $\rho < 0.005$ ), and must therefore be assigned to the totally symmetric stretching mode of a cubic (*i.e.*, in this case tetrahedral) molecule. Accordingly, all the fundamentals have been assigned on the basis of  $T_d$  symmetry for each molecule. The  $\nu_1(a_1)$  band is very strong and comparatively sharp in each case; it has no rotational structure in agreement with the appropriate selection rules.<sup>19</sup> By contrast, the fundamental of highest frequency for each molecule is very weak and is accordingly assigned to the  $\nu_3(t_2)$  mode. Its frequency agrees well with the corresponding infrared value in the two cases for which this comparison is possible, *viz.*, ZrCl<sub>4</sub> 421 cm<sup>-1</sup> (infrared),<sup>6</sup> 418 cm<sup>-1</sup> (Raman); HfCl<sub>4</sub> 393 cm<sup>-1</sup> (infrared),<sup>6</sup> 390 cm<sup>-1</sup> (Raman). Although the expected rotational structure of this band

could not be resolved owing to the weakness of the band, the latter is considerably broader than the band associated with the  $\nu_1(a_1)$  band, presumably on this account.

For all tetrahedral molecules, the  $\nu_2(e)$  mode lies at a lower frequency than the  $\nu_4(t_2)$  mode, this having in general been established by the existence of an infrared-Raman coincidence for the latter but not for the former. Accordingly we have assigned these two fundamentals of the present molecules in the same relative frequency order. The band envelopes of the two bending modes of each molecule tend to overlap, in some cases seriously, owing to pronounced rotational structure of each band. On intensity grounds,<sup>19</sup> this structure is expected to arise from OQS as well as PQR branches. The Q branch of the  $\nu_2(e)$  mode shows up clearly in all cases except for hafnium tetraiodide. However, that of the  $\nu_4(t_2)$  mode is frequently difficult to locate accurately; this situation arises partly because of the close proximity of the two fundamentals to each other and partly because of Coriolis interactions between the two modes. The detailed form of these interactions and the procedure used to decide upon the value of the  $\nu_4(t_2)$  mode in such cases will be discussed elsewhere in conjunction with a study of the vapor-phase spectra of the group IVb tetrahalides.<sup>20</sup> However, the situation is typified by that for titanium tetrachloride, for which the separation of the branch maxima at 65° is *ca.* 13 cm<sup>-1</sup> for the  $\nu_2(e)$  mode and *ca.* 12 cm<sup>-1</sup> for the  $\nu_4(t_2)$  mode (Figure 2). The two Q branches are readily recognized by the fact that their separation (22 cm<sup>-1</sup>) is close to that in cyclohexane solution. The situation is more difficult with the zirconium and hafnium tetrachlorides, because in these cases, the intensity of the  $\nu_4(t_2)$  mode appears to be considerably less than that of the  $\nu_2(e)$  mode. Values for the Q branches of each fundamental only are quoted in Table I.

The vapor-phase infrared spectrum of zirconium tetrachloride has been reported<sup>6</sup> in the range 200–900 cm<sup>-1</sup>. In addition to the  $\nu_3(t_2)$  fundamental, a large number of combination bands and overtones were observed. The values for the four fundamentals deduced therefrom ( $\nu_1$  388,  $\nu_2$  102,  $\nu_3$  421,  $\nu_4$  112 cm<sup>-1</sup>) agree moderately well with those found directly herein (377, 98, 418, and 113 cm<sup>-1</sup>, respectively).

**Force Constant Calculations.**—Force constants for the molecules have been calculated<sup>21</sup> both on the basis of the modified valence force field (MVFF) as well as on the basis of the Urey-Bradley force field (UBFF) and the results are given in Tables II and III. As commonly occurs in force constant calculations, two mathematically correct sets of solutions are obtained for the force-field equations. In the MVFF case, the solution has been taken which contains the smaller values of the interaction force constants. The discarded solution contains an interaction force constant which is nearly as large as the stretching force constant. In the UBFF case the solution has been taken which contains the larger stretching force constant. The discarded solution contains a stretching force constant of less than 0.1 mdyn Å<sup>-1</sup> and large negative interaction constants. The force constants are not, of course, chemi-

(17) A. Suvarov and E. K. Krzhizhanovskaya, *Russ. J. Inorg. Chem.*, **14**, 434 (1969).

(18) J. Weidlein, U. Müller, and K. Dehnicke, *Spectrochim. Acta, Part A*, **24**, 253 (1968).

(19) G. Herzberg, "Infrared and Raman Spectra of Polyatomic Molecules," Van Nostrand, Princeton, N. J., 1945.

(20) R. J. H. Clark and D. M. Rippon, *Chem. Commun.*, 1297 (1971), and work in preparation.

(21) A. Müller and B. Krebs, *J. Mol. Spectrosc.*, **24**, 180 (1967).

TABLE II  
MVFF FORCE CONSTANTS<sup>a</sup> (MDYN Å<sup>-1</sup>) FOR  
THE GROUP IV TETRAHALIDES

Halide	$f_r$	$f_\alpha$	$f_{rr}$	$f_{\alpha\alpha}$
TiCl <sub>4</sub>	2.663	0.101	0.165	0.005
TiBr <sub>4</sub>	2.196	0.083	0.109	0.005
TiI <sub>4</sub>	1.640	0.074	0.107	0.004
ZrCl <sub>4</sub>	2.514	0.081	0.151	0.007
ZrBr <sub>4</sub>	2.157	0.061	0.078	0.002
ZrI <sub>4</sub>	1.664	0.052	0.067	0.003
HfCl <sub>4</sub>	2.631	0.093	0.138	0.011
HfBr <sub>4</sub>	2.268	0.069	0.114	0.003
HfI <sub>4</sub>	1.849	0.078	0.005	0.002

<sup>a</sup> 1 mdyn Å<sup>-1</sup> = 10<sup>2</sup> N m<sup>-1</sup>: A. Müller and B. Krebs, *J. Mol. Spectrosc.*, 24, 180 (1967). In this approximation,  $f_{\alpha\alpha'} = 0$  and  $f_{r\alpha} = f_{r\alpha'}$ .

TABLE III  
UREY-BRADLEY FORCE CONSTANTS<sup>a</sup> (MDYN Å<sup>-1</sup>)  
FOR THE GROUP IV TETRAHALIDES

Halide	$K$	$H$	$F$	$F'$
TiCl <sub>4</sub>	2.509	0.035	0.163	-0.005
TiBr <sub>4</sub>	2.150	0.042	0.093	-0.003
TiI <sub>4</sub>	1.619	0.036	0.086	-0.002
ZrCl <sub>4</sub>	2.296	0.008	0.168	-0.010
ZrBr <sub>4</sub>	2.093	0.031	0.075	-0.002
ZrI <sub>4</sub>	1.627	0.025	0.060	-0.003
HfCl <sub>4</sub>	2.373	0.010	0.168	-0.017
HfBr <sub>4</sub>	2.117	0.020	0.123	-0.004
HfI <sub>4</sub>	1.844	0.073	0.005	-0.002

<sup>a</sup> 1 mdyn Å<sup>-1</sup> = 10<sup>2</sup> N m<sup>-1</sup>: A. Müller and B. Krebs, *J. Mol. Spectrosc.*, 24, 180 (1967).

cally significant to the number of figures quoted, on account of the possible uncertainty in the frequencies of the fundamentals; however, they are quoted as given because in this way they will regenerate the fundamentals to within 0.1 cm<sup>-1</sup>. The only force constant sufficiently large to warrant discussion is the bond stretching force constant ( $f_r$  in the MVFF,  $K$  in the UBFF). This constant behaves in the same way in the two force fields. It is very little dependent on the central metal atom, but it decreases in the order MCl > MBr > MI for both force fields, the average values being 2.60, 2.21, and 1.72, respectively, for the MVFF case, and 2.40, 2.12, and 1.70 mdyn Å<sup>-1</sup>, respectively for the UBFF case. This behavior appears to be typical of halide complexes in this part of the periodic table; in particular, the same dependence of metal-halogen bond stretching force constants on the halogen has been found for the MX<sub>6</sub><sup>2-</sup> ions.<sup>22</sup>

**Thermodynamic Functions.**—Values for a number of thermodynamic functions of the nine tetrahalides have been calculated in each case for 1 mol of the ideal gas at 1 atm pressure and at a number of different temperatures. The functions are  $H^\circ_T - H^\circ_{298}$ ,  $-(G^\circ_T - H^\circ_{298})/T$ ,  $S^\circ_T$ , and  $C_p^\circ$ . The calculations were based on the <sup>12</sup>C atomic weight scale and the N. A. S. tables of physical constants, the rigid-rotor harmonic oscillator approximation, a singlet ground electronic state, and a symmetry number of 12. Contributions from nuclear spin, anharmonicity, centrifugal distortion, and isotope mixing to the functions were omitted. The results are given in Tables IV–XII and are based on the values for the fundamentals and bond lengths given in Table I.

Less complete tables of similar data have previously been published for three of the tetrahalides, TiCl<sub>4</sub>,

TABLE IV  
CALCULATED THERMODYNAMIC PROPERTIES OF  
TITANIUM TETRACHLORIDE IN THE VAPOR STATE

$T$ , °K	$C_p^\circ$ , cal deg <sup>-1</sup> mol <sup>-1</sup>	$H^\circ_T - H^\circ_{298}$ , <sup>a</sup> cal mol <sup>-1</sup>	$-(G^\circ_T - H^\circ_{298})/T$ , cal deg <sup>-1</sup> mol <sup>-1</sup>	$S^\circ_T$ , cal deg <sup>-1</sup> mol <sup>-1</sup>
100	15.98	-3,991	103.03	63.12
150	18.59	-3,123	90.94	70.12
200	20.54	-2,142	86.46	75.75
250	21.91	-1,079	84.80	80.49
298.15	22.83	0	84.43	84.43
300	22.86	42	84.43	84.57
350	23.52	1,203	84.71	88.15
400	24.00	2,392	85.35	91.33
450	24.34	3,601	86.17	94.17
500	24.60	4,825	87.10	96.75
600	24.96	7,304	89.10	101.27
700	25.18	9,812	91.12	105.14
800	25.32	12,338	93.09	108.51
900	25.43	14,876	94.97	111.50
1000	25.50	17,423	96.76	114.18

<sup>a</sup>  $H^\circ_{298} - H^\circ_0 = 5142$  cal mol<sup>-1</sup>.

TABLE V  
CALCULATED THERMODYNAMIC PROPERTIES OF  
TITANIUM TETRABROMIDE IN THE VAPOR STATE

$T$ , °K	$C_p^\circ$ , cal deg <sup>-1</sup> mol <sup>-1</sup>	$H^\circ_T - H^\circ_{298}$ , <sup>a</sup> cal mol <sup>-1</sup>	$-(G^\circ_T - H^\circ_{298})/T$ , cal deg <sup>-1</sup> mol <sup>-1</sup>	$S^\circ_T$ , cal deg <sup>-1</sup> mol <sup>-1</sup>
100	18.36	-4,353	115.66	72.13
150	20.79	-3,370	102.53	80.06
200	22.38	-2,288	97.72	86.28
250	23.38	-1,142	95.96	91.39
298.15	24.00	0	95.57	95.57
300	24.03	44	95.57	95.71
350	24.46	1,257	95.86	99.45
400	24.75	2,488	96.52	102.74
450	24.96	3,731	97.38	105.67
500	25.12	4,983	98.34	108.31
600	25.33	7,507	100.39	112.91
700	25.46	10,047	102.47	116.82
800	25.55	12,597	104.48	120.23
900	25.60	15,155	106.40	123.24
1000	25.65	17,717	108.22	125.94

<sup>a</sup>  $H^\circ_{298} - H^\circ_0 = 5714$  cal mol<sup>-1</sup>.

TABLE VI  
CALCULATED THERMODYNAMIC PROPERTIES OF  
TITANIUM TETRAIODIDE IN THE VAPOR STATE

$T$ , °K	$C_p^\circ$ , cal deg <sup>-1</sup> mol <sup>-1</sup>	$H^\circ_T - H^\circ_{298}$ , <sup>a</sup> cal mol <sup>-1</sup>	$-(G^\circ_T - H^\circ_{298})/T$ , cal deg <sup>-1</sup> mol <sup>-1</sup>	$S^\circ_T$ , cal deg <sup>-1</sup> mol <sup>-1</sup>
100	19.82	-4,554	123.90	78.35
150	22.07	-3,503	110.20	86.85
200	23.38	-2,363	105.21	93.40
250	24.14	-1,174	103.40	98.70
298.15	24.59	0	103.00	103.00
300	24.60	46	103.00	103.15
350	24.91	1,284	103.30	106.97
400	25.11	2,534	103.97	110.31
450	25.26	3,794	104.84	113.27
500	25.36	5,059	105.82	115.94
600	25.50	7,603	107.90	120.58
700	25.59	10,158	110.00	124.51
800	25.64	12,720	112.03	127.93
900	25.68	15,286	113.97	130.96
1000	25.71	17,856	115.81	133.66

<sup>a</sup>  $H^\circ_{298} - H^\circ_0 = 6050$  cal mol<sup>-1</sup>.

TiBr<sub>4</sub>, and ZrCl<sub>4</sub>. In the case of titanium tetrachloride,<sup>11</sup> the data were then based on a slightly inaccurate titanium-chlorine bond length (2.18 Å) and on values for  $\nu_1$ ,  $\nu_2$ , and  $\nu_4$  as determined from infrared-active combination bands. The original data on titanium tetrabromide were based on liquid-state values for the fundamentals, which, as discussed earlier, differ significantly from those reported herein. The originally

(22) W. van Bronswyk, R. J. H. Clark, and L. Maresca, *Inorg. Chem.*, 8, 1395 (1969).

TABLE VII  
CALCULATED THERMODYNAMIC PROPERTIES OF  
ZIRCONIUM TETRACHLORIDE IN THE VAPOR STATE

T, °K	$C_p^\circ$ , cal deg <sup>-1</sup> mol <sup>-1</sup>	$H^\circ_T - H^\circ_{298}$ , <sup>a</sup> cal mol <sup>-1</sup>	$-(G^\circ_T - H^\circ_{298})/T$ , cal deg <sup>-1</sup> mol <sup>-1</sup>	$S^\circ_T$ , cal deg <sup>-1</sup> mol <sup>-1</sup>
100	16.92	-4,165	107.20	65.55
150	19.59	-3,249	94.61	72.95
200	21.47	-2,219	89.95	78.86
250	22.70	-1,113	88.24	83.79
298.15	23.48	0	87.86	87.86
300	23.50	43	87.86	88.00
350	24.05	1,233	88.15	91.67
400	24.43	2,445	88.79	94.91
450	24.70	3,674	89.64	97.80
500	24.90	4,914	90.59	100.41
600	25.17	7,419	92.62	104.98
700	25.34	9,945	94.67	108.88
800	25.46	12,486	96.66	112.27
900	25.53	15,035	98.56	115.27
1000	25.59	17,592	100.37	117.96

<sup>a</sup>  $H^\circ_{298} - H^\circ_0 = 5392$  cal mol<sup>-1</sup>.

TABLE VIII  
CALCULATED THERMODYNAMIC PROPERTIES OF  
ZIRCONIUM TETRABROMIDE IN THE VAPOR STATE

T, °K	$C_p^\circ$ , cal deg <sup>-1</sup> mol <sup>-1</sup>	$H^\circ_T - H^\circ_{298}$ , <sup>a</sup> cal mol <sup>-1</sup>	$-(G^\circ_T - H^\circ_{298})/T$ , cal deg <sup>-1</sup> mol <sup>-1</sup>	$S^\circ_T$ , cal deg <sup>-1</sup> mol <sup>-1</sup>
100	19.37	-4,521	119.81	74.59
150	21.84	-3,486	106.20	82.96
200	23.25	-2,355	101.23	89.45
250	24.06	-1,171	99.42	94.74
298.15	24.53	0	99.02	99.02
300	24.55	45	99.02	99.17
350	24.87	1,281	99.32	102.98
400	25.08	2,530	99.99	106.31
450	25.23	3,788	100.86	109.28
500	25.34	5,053	101.84	111.94
600	25.49	7,595	103.92	116.58
700	25.58	10,149	106.01	120.51
800	25.64	12,710	108.05	123.93
900	25.68	15,275	109.98	126.95
1000	25.71	17,845	111.82	129.66

<sup>a</sup>  $H^\circ_{298} - H^\circ_0 = 5962$  cal mol<sup>-1</sup>.

TABLE IX  
CALCULATED THERMODYNAMIC PROPERTIES OF  
ZIRCONIUM TETRAIODIDE IN THE VAPOR STATE

T, °K	$C_p^\circ$ , cal deg <sup>-1</sup> mol <sup>-1</sup>	$H^\circ_T - H^\circ_{298}$ , <sup>a</sup> cal mol <sup>-1</sup>	$-(G^\circ_T - H^\circ_{298})/T$ , cal deg <sup>-1</sup> mol <sup>-1</sup>	$S^\circ_T$ , cal deg <sup>-1</sup> mol <sup>-1</sup>
100	20.94	-4,706	128.16	81.10
150	23.06	-3,599	114.04	90.04
200	24.11	-2,417	108.92	96.84
250	24.67	-1,196	107.07	102.28
298.15	25.00	0	106.66	106.66
300	25.01	46	106.66	106.81
350	25.22	1,302	106.96	110.69
400	25.36	2,567	107.65	114.06
450	25.45	3,837	108.53	117.05
500	25.52	5,112	109.52	119.74
600	25.62	7,669	111.62	124.40
700	25.67	10,234	113.74	128.36
800	25.71	12,803	115.78	131.79
900	25.74	15,375	117.73	134.82
1000	25.75	17,950	119.58	137.53

<sup>a</sup>  $H^\circ_{298} - H^\circ_0 = 6288$  cal mol<sup>-1</sup>.

TABLE X  
CALCULATED THERMODYNAMIC PROPERTIES OF  
HAFNIUM TETRACHLORIDE IN THE VAPOR STATE

T, °K	$C_p^\circ$ , cal deg <sup>-1</sup> mol <sup>-1</sup>	$H^\circ_T - H^\circ_{298}$ , <sup>a</sup> cal mol <sup>-1</sup>	$-(G^\circ_T - H^\circ_{298})/T$ , cal deg <sup>-1</sup> mol <sup>-1</sup>	$S^\circ_T$ , cal deg <sup>-1</sup> mol <sup>-1</sup>
100	17.05	-4,208	108.57	66.49
150	19.84	-3,282	95.84	73.96
200	21.71	-2,239	91.14	79.95
250	22.90	-1,122	89.42	84.93
298.15	23.65	0	89.03	89.03
300	23.67	44	89.03	89.18
350	24.18	1,241	89.32	92.87
400	24.54	2,459	89.97	96.12
450	24.79	3,693	90.82	99.03
500	24.98	4,937	91.77	101.65
600	25.23	7,448	93.81	106.23
700	25.38	9,980	95.87	110.13
800	25.49	12,524	97.87	113.53
900	25.56	15,076	99.78	116.53
1000	25.61	17,635	101.59	119.23

<sup>a</sup>  $H^\circ_{298} - H^\circ_0 = 5435$  cal mol<sup>-1</sup>.

TABLE XI  
CALCULATED THERMODYNAMIC PROPERTIES OF  
HAFNIUM TETRABROMIDE IN THE VAPOR STATE

T, °K	$C_p^\circ$ , cal deg <sup>-1</sup> mol <sup>-1</sup>	$H^\circ_T - H^\circ_{298}$ , <sup>a</sup> cal mol <sup>-1</sup>	$-(G^\circ_T - H^\circ_{298})/T$ , cal deg <sup>-1</sup> mol <sup>-1</sup>	$S^\circ_T$ , cal deg <sup>-1</sup> mol <sup>-1</sup>
100	19.84	-4,597	121.20	75.23
150	22.33	-3,536	107.37	83.80
200	23.63	-2,384	102.34	90.42
250	24.34	-1,183	100.51	95.78
298.15	24.75	0	100.10	100.10
300	24.76	46	100.10	100.26
350	25.03	1,291	100.41	104.09
400	25.21	2,548	101.08	107.45
450	25.34	3,812	101.96	110.53
500	25.43	5,081	102.94	113.10
600	25.55	7,630	105.03	117.75
700	25.62	10,190	107.14	121.69
800	25.67	12,755	109.18	125.12
900	25.71	15,324	111.12	128.15
1000	25.73	17,896	112.96	130.86

<sup>a</sup>  $H^\circ_{298} - H^\circ_0 = 6049$  cal mol<sup>-1</sup>.

TABLE XII  
CALCULATED THERMODYNAMIC PROPERTIES OF  
HAFNIUM TETRAIODIDE IN THE VAPOR STATE

T, °K	$C_p^\circ$ , cal deg <sup>-1</sup> mol <sup>-1</sup>	$H^\circ_T - H^\circ_{298}$ , <sup>a</sup> cal mol <sup>-1</sup>	$-(G^\circ_T - H^\circ_{298})/T$ , cal deg <sup>-1</sup> mol <sup>-1</sup>	$S^\circ_T$ , cal deg <sup>-1</sup> mol <sup>-1</sup>
100	21.28	-4754	127.62	80.09
150	23.38	-3630	113.37	89.17
200	24.34	-2434	108.21	96.04
250	24.84	-1203	106.35	101.53
298.15	25.12	0	105.94	105.94
300	25.13	46	105.94	106.09
350	25.31	1,308	106.24	109.98
400	25.43	2,577	106.93	113.37
450	25.51	3,850	107.81	116.37
500	25.57	5,127	108.80	119.06
600	25.65	7,689	110.91	123.73
700	25.70	10,257	113.03	127.69
800	25.73	12,828	115.09	131.12
900	25.75	15,402	117.04	134.15
1000	25.77	17,978	118.89	136.87

<sup>a</sup>  $H^\circ_{298} - H^\circ_0 = 6307$  cal mol<sup>-1</sup>.

published tables of thermodynamic functions of zirconium tetrachloride<sup>6</sup> were also based on somewhat different values for its four fundamentals from those reported herein, values determined (except for  $\nu_3(t_2)$ ) from combination bands as discussed previously; the zirconium-chlorine bond length was not specified. In none of these three cases, however, do the present

tables differ greatly from those mentioned above. In addition to the above, however, similar data are available in the "JANAF Thermochemical Tables"<sup>23</sup> for the tetrahalides of titanium and zirconium. The data therein for titanium tetrachloride and titanium tetra-

(23) "JANAF Thermochemical Tables," Air Force Contract AF 04(611)-7554, 1965.

bromide are based on the fundamental frequencies reported by Hawkins and Carpenter<sup>12</sup> and by Miller and Carlson<sup>14</sup> which have already been discussed; the maximum difference between the literature value and the present value for any fundamental is 5 cm<sup>-1</sup> for the tetrachloride and 10 cm<sup>-1</sup> for the tetrabromide. The data in the JANAF tables for zirconium tetrachloride are in error owing to their being based on a grossly inaccurate value<sup>24</sup> for  $\nu_1(a_1)$  (315 cm<sup>-1</sup> vs. the correct value of 377 cm<sup>-1</sup>) and on estimated values for  $\nu_2(e)$  and  $\nu_4(t_2)$  (these being in error by up to 6 cm<sup>-1</sup>). The data in the JANAF tables for the halides TiI<sub>4</sub>, Zr-Br<sub>4</sub>, and ZrI<sub>4</sub> are entirely based on estimated values for

(24) Ya. S. Bobavich, *Opt. Spektrosk.*, **11**, 85 (1961).

the four fundamentals in each case; these estimates are in error to the maximum extent of 63 cm<sup>-1</sup> for titanium tetraiodide, 9 cm<sup>-1</sup> for zirconium tetrabromide, and 17 cm<sup>-1</sup> for zirconium tetraiodide. Tables VII–XII therefore place, for the first time, the very close similarities between the tetrahalides of zirconium and hafnium on a quantitative basis.<sup>25</sup>

**Acknowledgment.**—B. K. H. thanks the N.R.C. for a fellowship and D. M. R. thanks the S.R.C. for a studentship. The authors thank Dr. C. J. Willis for his assistance in the design of the hot cell.

(25) NOTE ADDED IN PROOF.—Revised values for the fundamentals and the thermodynamic properties of lead tetrachloride have recently been published; see R. J. H. Clark and B. K. Hunter, *J. Mol. Struct.*, **9**, 354 (1971).

CONTRIBUTION FROM THE DEPARTMENT OF CHEMISTRY, REVELLE COLLEGE, UNIVERSITY OF CALIFORNIA, SAN DIEGO, LA JOLLA, CALIFORNIA 92037

## Kinetics and Mechanism of the Reduction of Hydrazoic Acid by Chromium(II) and Vanadium(II)

By R. G. LINCK

Received May 20, 1971

The rates of reduction of HN<sub>3</sub> by V(II) and Cr(II) are reported. Both reactions produce 1 mol of N<sub>2</sub> and 1 mol of NH<sub>3</sub> and consume 2 mol of reductant. Both reductions proceed by mixed second-order kinetics with the rate constant independent of [H<sup>+</sup>] over the range 0.1–1.0 M. For the rate law defined by  $-d[\text{HN}_3]/dt = k[\text{HN}_3][\text{reductant}]$ , the rate parameters are: for Cr<sup>2+</sup>  $k = 18 \text{ M}^{-1} \text{ sec}^{-1}$ ,  $\Delta H^\ddagger = 7.1 \text{ kcal mol}^{-1}$ , and  $\Delta S^\ddagger = -29 \text{ cal mol}^{-1} \text{ deg}^{-1}$ ; for V<sup>2+</sup>  $k = 2.8 \times 10^{-2} \text{ M}^{-1} \text{ sec}^{-1}$ ,  $\Delta H^\ddagger = 14.4 \text{ kcal mol}^{-1}$ , and  $\Delta S^\ddagger = -17 \text{ cal mol}^{-1} \text{ deg}^{-1}$ , all at 25°. The reaction of Cr<sup>2+</sup> with HN<sub>3</sub> produces a Cr–N bond in the first step. The fate of the unstable species produced thereafter is discussed.

### Introduction

The role a reducible ligand plays in redox reactions between metal ions has become a topic of considerable interest since Nordmeyer and Taube produced convincing evidence of a radical ion intermediate in the Cr<sup>2+</sup> reduction of isonicotinamidopentaamminecobalt(III) complex.<sup>1</sup> One feature of this interest involves the study of the rate and mechanism of reduction of free ligands. A detailed study of the V<sup>2+</sup> reduction of cobalt(III)–azide complexes<sup>2</sup> made information about the V<sup>2+</sup> reduction of hydrazoic acid necessary. Several preliminary experiments indicated that the Cr<sup>2+</sup> reduction of HN<sub>3</sub>, which has been examined previously,<sup>3,4</sup> was not satisfactorily understood. In this report a description of the kinetics and mechanism of the reduction of HN<sub>3</sub> by these two reagents is given. Of interest in these noncomplimentary reactions is the fate of unstable, intermediate, oxidation states; these are discussed.

### Experimental Section

**Reagents and Analyses.**—The sodium azide was an Eastman product and was recrystallized from water as described by Browne.<sup>5</sup> A solution of this solid was analyzed by adding the NaN<sub>3</sub> solution to excess Ce(IV) and titrating that excess with standard Fe(II) solution to a ferroin end point.<sup>6</sup>

Solutions of Cr(II) were derived from Cr(III) solutions by reduction with amalgamated Zn. The Cr(III) stock solution was prepared by H<sub>2</sub>O<sub>2</sub> reduction of CrO<sub>3</sub> in HClO<sub>4</sub>. Total Cr(III) content was determined by oxidation with peroxide of an aliquot made basic using  $\epsilon$  4815 at 3730 Å.<sup>7</sup> The [ClO<sub>4</sub><sup>-</sup>] of the stock Cr(III) solution was determined by ion exchange of an aliquot on Dowex 50W-X8 in the H<sup>+</sup> form and titration of the acid released with standard base. Reducing power of the Cr(II) solution was measured by adding an aliquot to deaerated Ce(IV) solution in H<sub>2</sub>SO<sub>4</sub> medium<sup>8</sup> followed by titration of the excess Ce(IV) with standard Fe(II). The concentration of total cations (exclusive of H<sup>+</sup>) was determined by heating an aliquot of the Cr(II) solution with excess EDTA buffered at pH 5 for 5–15 min at 80°;<sup>9</sup> after raising the pH to 10 with NH<sub>3</sub>–NH<sub>4</sub>Cl buffer, the excess EDTA was titrated with standard Zn<sup>2+</sup> to an Erio-Black-T end point.

Solutions of VO<sup>2+</sup> were prepared either by electrolytic reduction of V<sub>2</sub>O<sub>5</sub> in HClO<sub>4</sub> acid or by treatment of a solution of VOSO<sub>4</sub> with an anion-exchange resin in the ClO<sub>4</sub><sup>-</sup> form. No differences in rate behavior between the two solutions were observed. Reduction was accomplished with amalgamated Zn. When not in use this solution of V(II) was stored at –78° in order to prevent reduction of ClO<sub>4</sub><sup>-</sup>. Total V was determined spectrophotometrically as the peroxide complex;<sup>10</sup> [ClO<sub>4</sub><sup>-</sup>] was determined as outlined above. Analysis for total reducing power utilized the cerimetric technique described for [Cr(II)], except that the excess Ce(IV) was titrated with Fe(II) in a solution >5 M in H<sub>2</sub>SO<sub>4</sub> in order to reduce VO<sub>2</sub><sup>+</sup> before Fe(phen)<sub>3</sub><sup>3+</sup>.<sup>11</sup> The [V<sup>2+</sup>] + [V<sup>3+</sup>] + [Zn<sup>2+</sup>] was determined by an EDTA titration after oxidation of V<sup>2+</sup> with ClO<sub>2</sub><sup>-</sup> or NO<sub>3</sub><sup>-</sup>.

(1) F. Nordmeyer and H. Taube, *J. Amer. Chem. Soc.*, **90**, 1163 (1968).  
 (2) K. Hicks, D. L. Toppen, and R. G. Linck, unpublished observations.  
 (3) M. Ardon and B. E. Mayer, *J. Chem. Soc.*, 2819 (1962).  
 (4) C. F. Wells and M. A. Salem, *ibid.*, **A**, 1568 (1968).  
 (5) A. W. Browne, *Inorg. Syn.*, **1**, 79 (1939).  
 (6) J. W. Arnold, *Ind. Eng. Chem., Anal. Ed.*, **17**, 215 (1945).

(7) G. Haupt, *J. Res. Nat. Bur. Stand.*, **48**, 414 (1952).  
 (8) J. Y. Tong and E. L. King, *J. Amer. Chem. Soc.*, **82**, 3805 (1960).  
 (9) G. Doppler and R. Patzak, *Z. Anal. Chem.*, **152**, 45 (1956).  
 (10) P. R. Guenther and R. G. Linck, *J. Amer. Chem. Soc.*, **91**, 3769 (1969).  
 (11) G. P. Walden, Jr., L. P. Hammett, and S. M. Edmonds, *ibid.*, **56**, 57 (1934).